

Lionginas LIUDVINAVIČIUS
Leonas Povilas LINGAITIS
Gintautas BUREIKA

INVESTIGATION ON WHEEL-SETS SLIP AND SLIDE CONTROL PROBLEMS OF LOCOMOTIVES WITH AC TRACTION MOTORS

BADANIE PROBLEMÓW BUKSOWANIA KOŁOWEGO I STEROWANIA PROCESU ŚLIZGANIA W LOKOMOTYWACH Z SILNIKAMI TRAKCJI ASYNCHRONICZNEJ

The article is dedicated to the solution of drive parameter adjustment and correction problems of AC traction motors. Having assessed different rail adhesion ratios and AC electrical machine operation peculiarities, there have been proposed new dynamic slip and slide process control methods to DC/AC, AC/AC current system locomotives. There is described the influence of mechanical characteristics of AC traction motors to the formation of wheel slip process and there are provided structural control schemes of the dynamic slip process. The slip process formation and control conditions for wheel pairs are provided in mathematical and graphical forms. There are provided automatic control parameters of dynamic slip and slide process for AC/AC current locomotives.

Keywords: diesel-electric locomotives, AC traction motor, slip-slide control system, adhesion coefficient, traction generator characteristics, anti-slip drive.

Artykuł jest przeznaczony dla rozwiązania problemów regulowania i korekcji parametrów pracy przekładni lokomotywy z silnikiem trakcyjnym AC. Oceniając różne czynniki przyczepności koła lokomotywy z torem i osobliwości maszyn elektrycznych typu AC, w artykule przedstawiono nowe metody buksowania dynamicznego i sterowania procesu ślizgania przekładni lokomotywy dla systemów prądu AC/DC, AC/AC. Oceniając wpływ rodzaju charakterystyk mechanicznych silników trakcyjnych AC na formowanie procesu buksowania kół, w artykule przedstawiono strukturalne schematy sterowania procesów buksowania dynamicznego. Formowanie procesu buksowania par kół i warunki jego sterowania przedstawiono w wyrażeniu matematycznym i formie graficznej. W artykule zaprezentowano parametry buksowania dynamicznego i sterowania automatycznego procesu ślizgania dla lokomotywy systemów prądu AC/AC.

Słowa kluczowe: lokomotywa elektryczna z silnikiem Diesla, silniki trakcji AC, system sterowania buksowania i ślizgania, współczynnik przyczepności, przekładnia antyślizgowa.

1. Introduction

The main income (over 90%) of the Lithuanian state railway transport company "Lietuvos geležinkeliai" Plc. comes from freight transportation. Thus it is very important to ensure continuous and stable freight train traffic by transporting the biggest possible cargo amounts. The most intensive freight flows as well as the heaviest freight rolling stocks cross Lithuanian railways from Belorussia to the harbors of the Baltic sea, i.e. Klaipeda and Kaliningrad. When carrying heavy rolling stocks, especially if it is necessary to move standstill rolling stocks or get over steep and long slopes, locomotives face the problem how to ensure stable traction mode, i.e. the phenomenon of locomotive wheel set slip and slide. The locomotive interaction with rails and the causes of their slip have been analyzed by many researchers all over the world. In case of drive wheel slip and slide there is a sudden drop of locomotive traction force as well as train speed. The train may be stopped at the uphill, thus disturbing (or even interrupting) side track traffic. The phenomena of train stable driving uphill were described by Bureika [4],

by Liudvinavičius et al [11]. In case of movement of standstill trains and sliding of locomotive wheels, there is no sufficient traction force to move the locomotive.

However if sand is put under the sliding wheels the adhesion of drive wheels with the rails shall increase several times and, moreover, there shall be a rapid increase of the traction force. This force has a negative effect on rolling stocks as a huge amount of shock force is transferred to the whole rolling stock length through automatic coupling point. This shock force affects rolling stock structures (frames, bodies, suspensions, carriages, etc.) and can harm cargos and as well as their packaging. These problems were analyzed by Bąk et al [2], Jastremskas et al [7].

There have been theoretical assumptions of locomotive wheel set slip and slide causes when carrying out the research. The article discusses theoretical and practical aspects of formation of wheel set rolling surface conicality, rail tilt angle and wheel pair position in the track, redistribution of locomotive drive wheel set axis force to rail in traction mode at slip conditions. There are analyzed peculiarities of locomotive adhesion

weight optimum usage, axis force change in traction mode. The influence of locomotive adhesion ratio change to traction characteristic and traction force change are described. There are examined various locomotive construction schemes with AC traction motor drive. Mechanical characteristics of AC traction motors are provided.

New generation diesel locomotives, e.g. SIEMENS ER-20CF use AC motors for wheel set traction motor that are significantly more reliable and unsophisticated if compared to the previous DC motors used for drives. The three-phase asynchronous traction motor is the motor used most frequently for modern locomotive drives because of its excellent reliability, its simple and thus low-cost construction and low maintenance costs. The three-phase asynchronous traction motor is also known as squirrel-cage rotor. On the other hand, AC motor rotation speed adjustment differs essentially from DC motor rotation speed change. Thus, aiming to control and adjust slip and slide processes of drive wheel sets it is necessary to apply different principles of electrical machine operation parameter tracking, measurement and adjustment. These issues are analysed by Lingaitis and Liudvinavičius [8]. Hereinafter the authors describe the causes of locomotive drive wheel slide and provide measures for the correction and control of slip and slide processes of locomotive wheel sets with AC traction motors.

Theoretical presumptions for locomotive slip formation and wheel set slide on rail consequences

The locomotive wheel set slippage is evident when the locomotive traction force exceeds adhesion force. The main locomotive traction law is the following:

$$F_{tr} \leq \Psi_{adh} \cdot P_{adh} \quad (1)$$

where: Ψ_{adh} – locomotive wheel-sets’ adhesion to rail coefficient; P_{adh} – locomotive adhesion weight, N.

In order to maintain stable traction mode (to avoid wheels slip) it is necessary to maintain formula (1) inequality condition. The change of locomotives wheel-sets adhesion coefficient value in different seasons is provided in figure 1

The estimation of adhesion coefficient of a newly made locomotive is carried out by means of practical tests in different seasons and different day time. In order to obtain objective results several hundred of practical tests are carried out. Figure 1 shows that adhesion coefficient values are highly dissipated as there are many factors that influence in case of equal train mass,

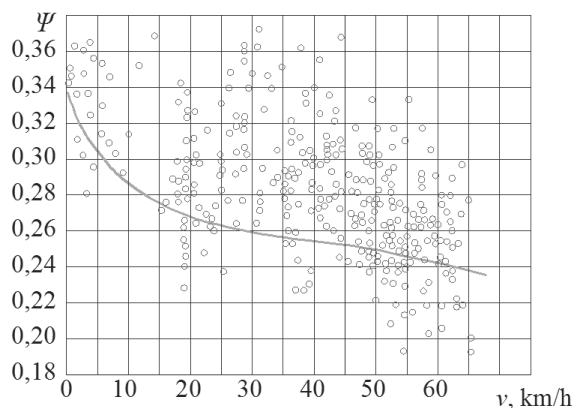

Fig. 1. Locomotive adhesion coefficient dissipation dependence on locomotive speed in different seasons

including rain, snow, rail contamination with oil products, etc. [16]. Traction characteristics of diesel-electric powered locomotive are provided in figure 2.

The diesel-electric powered locomotive adhesion coefficient value in the season change time (dissipated, e.g. 0.33 to 0.2) is as shown in figure 1. However, when operating the said diesel locomotives in season change time, the rolling stock mass is not adjusted due to the changes of adhesion conditions. Caused by the decrease of the adhesion coefficient the traction power becomes insufficient for this rolling stock towing. In such a case sand is sprinkled intensively to increase the adhesion coefficient. However locomotive starting traction time is increased due to intensive slipping, thus causing accelerated wheel set and rail wear.

3. Slipping process of locomotive drive wheel sets

3.1. Peculiarities of locomotive traction and train movement resistance force operation

The wheel to rail force redistribution scheme (in traction mode) of locomotive drive wheel set axle is provided in figure 3. The scheme illustrates the “rising” moments M_0 that emerge in the traction mode that decrease the wheel set force to the rail of the first wheel set by one value ΔP (rise up) and increase the axle load to the rail of the second wheel set ΔP (press down). Such torques are formed due to the traction force F_{tr} of locomotive drive wheel sets that acts as a wheel set tangent and the moment of train resistance force W_j that acts in the height of the automatic coupling point h .

Locomotive traction force at wheel rim and locomotive movement resistance force at automatic coupling point h form the force pair or the “rise” torque M_0 that decreases the load of locomotive front wheel set and increases the final wheel set to rail force. Thus, the least loaded wheel set shall be the first to lose the necessary adhesion with the rails. The most frequent slip occurs namely at the first wheel set. Locomotive traction force is also influenced by wheel set traction force unevenness. If less loaded wheel set produces bigger traction force, it starts slipping earlier (when the traction force it produces is smaller) and this decreases the total locomotive traction force.

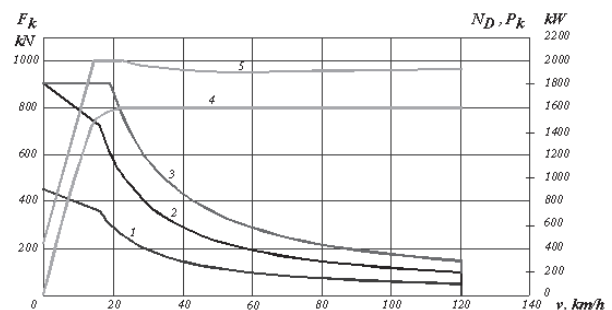

Fig. 2. Diesel-electric powered locomotive characteristics in traction mode: 1 – traction characteristics of one locomotive $F_k = f(v)$; 2 – traction characteristics of two locomotives; 3 – traction characteristics of three locomotives; 4 – locomotive power at wheel rim $P_k = f(v)$; 5 – Diesel engine power characteristics $N_D = f(v)$

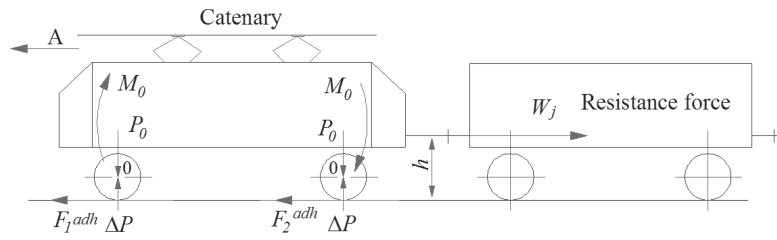

Fig. 3 Wheel to rail force redistribution scheme (in traction mode) of locomotive drive wheel set axle: F_1^{adh} and F_2^{adh} – drive wheel traction forces; P_0 – wheel-to-rail force; W_j – resistance force at automatic coupling point; h – height from the railhead to automatic coupling point.

3.2. Peculiarities of engine operation and location of wheel set to rail static force

Traction engine operation and the influence of its location to static wheel-to-rail force are especially significant when the suspension of traction motor is axial-supporting. Active forces and torques of the said situation are provided in figure 4. Traction motor achieves torque M_p that rotates wheel set. Traction motor shaft is connected to the wheel set via reducer. If the traction motor is located to the wheel set as shown in figure 3 and locomotive moves in the defined direction, force Z is directed upward.

Moreover, motor stator is influenced by torque $M_s = M_v$ that is applied to motor supports by force P_3 calculated as follows:

$$P_3 = \frac{M}{L} \quad (2)$$

Thus by locating the traction motor behind a wheel set and with supporting-frame suspension of the traction motor, the wheel to rail force is decreased by one value ΔP_r .

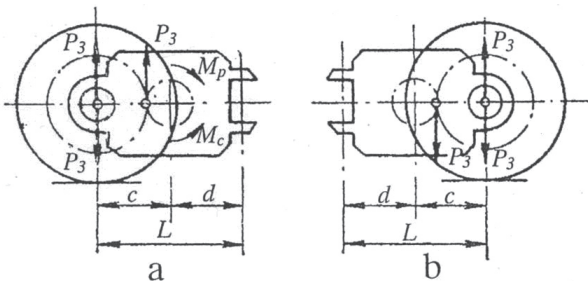

Fig. 4. Different schemes of electric traction motor dislocation influence on the wheel-force-to rail: P_3 – electric traction motor force to rail; M_p – motor torque applied to the motor shaft; M_c – resistance torque applied to traction motor shaft.

When locomotive changes its movement direction, the wheel to rail force increases by the same value.

3.3. Peculiarities of locomotive axle force change in traction mode

The bogie to rail force redistribution scheme (in traction mode) of the six-axle locomotive is provided in figure 5. Frames of bogies are affected by drive wheel set traction forces F_{a1}, \dots, F_{a6} and automatic coupling point of rolling stock is affected by movement resistance forces W_j that are equal $W_j = n \cdot F_{as}$. Due to the operation height difference of the traction force F_r generated by locomotive drive wheel sets and train movement resistance force W_j that acts at coupling point there is torque M_T :

$$M_T = n \cdot F_a \cdot (h - r_r) \quad (3)$$

where: n – wheel set number, units; F_a – traction force of one drive wheel set, N; h – coupling point height (distance from railhead to coupling point longitudinal axis), m; r_r – wheel set rolling radius, m.

Torque M_T tilts locomotive body at axis Y that crosses locomotive weight center C and it changes the value of vertical force T acting on bogies and it is calculated as follows:

$$T = M_T / B \quad (4)$$

where: B – distance between bogies (basis), m.

Wheel set force change ΔP_i is calculated as follows:

$$\Delta P_i = |R_T| = \frac{T}{m} = \frac{M_T}{m \cdot B} \quad (5)$$

where: m – bogie wheel set number.

At torque M_T the first bogie is less loaded and the second one is more loaded.

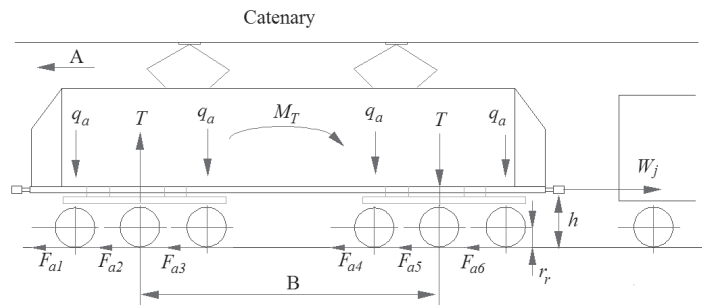

Fig. 5. Redistribution scheme of locomotive bogie to rail force: $F_{a1}, F_{a2}, F_{a3}, F_{a4}, F_{a5}, F_{a6}$ – traction forces of drive wheel sets; W_j – movement resistance forces that act on the rolling stock; q_a – static wheel to rail force of a wheel set; h – height from the railhead to automatic coupling point; B – distance between bogie centers (basis). A – locomotive's movement direction.

3.4. Peculiarities of locomotive adhesion coefficient changes

Locomotive traction force is influenced by inequalities of traction forces of every wheel set that are formed due to the uneven distribution of the locomotive weight between wheel sets. If less loaded locomotive wheel set produces too high traction force compared to the adhesion conditions, slipping shall be started at lower traction force thus lowering the total locomotive traction force. Adhesion coefficient is also influenced by rim erosion, rail wear and differences in wheel diameters of wheel sets. At road curves of small radius, wheel set adhesion to rail is worse due to wheel set slide caused by uneven distance that is traveled by a wheel of the wheel set. Adhesion coefficient depends on the locomotive electric drive type (AC/DC or AC/AC), traction motor connection type, nature of traction motor mechanical characteristics. The locomotive traction force may be decreased by the force due to wheel set force to rail redistribution and it is calculated as follows: $\Delta P + \Delta P_1 + \Delta P_2$. Force of the least loaded wheel set is calculated as follows:

$$2P_{\min} = q_a \cdot (1 - 0.03) - \Delta P \quad (6)$$

where: 0.03 – the tolerance of the static force to rail of wheel set according to technical locomotive characteristics with load q_a less than 225 kN.

Ratio of the least loaded wheel set and calculable force is called locomotive adhesion use coefficient β_k and it is expressed as follows:

$$\beta_k = \frac{q_{a\min}}{q_a} = \frac{q_a(r_r - 0,03) - \Delta P}{q_a} = 0,97 - \frac{\Delta P}{q_a} \quad (7)$$

Locomotive adhesion use coefficient shows the part of the traction force that is actually achieved by the locomotive. Having analyzed the said theoretical presumptions it can be said that locomotive adhesion use coefficient depends on wheel set and traction motor location, suspension type, nature of the traction motor mechanical characteristics.

4. Locomotive DC and AC traction motor speed-torque characteristics

Locomotive traction motor mechanical characteristics are in figure 6. Speed-torque characteristics of the DC and AC traction motor are described by Fuest and Döring [6]. The speed - torque natural characteristics are different [15].

Variation in load moment causes variation in speed. For locomotive traction force and wheel-sets slip requirements in starting mode the best is synchronous traction motor speed-torque characteristic (fig. 6, 1st curve). Figure 6 shows the speed-torque characteristic (1) curve of a synchronous traction motor. In the speed-torque characteristic the torque is usually shown dependent on the speed. Asynchronous traction motor and separately excited shunt - wound DC traction motor speed - torque characteristics a variation in load moment is similar-sized tolerance (fig. 6, 1st and 3rd curves). Locomotive with this traction motor speed-torque characteristics rarely comprise wheel-set slip conditions. The 4th curve (in fig. 6) shows that for locomotive with DC series-wound traction motors anti-slip systems must be used because when it is operated without load torque speed increases very quickly.

Figure 6 shows the speed-torque characteristic 2nd curve of a three-phase asynchronous traction motor. In the speed-to-

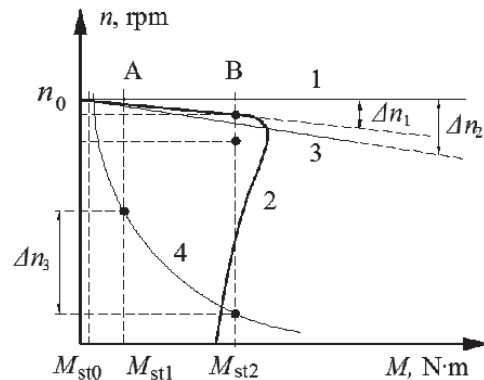

Fig. 6. Speed-torque characteristics of the DC and AC traction motor: 1 – synchronous traction motor; 2 – asynchronous traction motor speed-torque characteristics; 3 – individually excited shunt-wound DC traction motor; 4 – series wound DC traction, speed-torque characteristics; Δn_1 – asynchronous traction motor speed variation; Δn_2 – separately excited shunt - wound DC traction motor speed variation; Δn_3 – series wound DC traction speed variation

orque characteristic, the torque is usually shown dependent on the speed. There $M = 0$ when the motor is idling. If a load is applied to the motor, the speed drops and the torque increases. The maximum torque which a motor can produce is known as the pull-out torque.

5. Parallel operation and control peculiarities of AC traction motors

Principal scheme of AC/AC electrical system locomotive electrical drive when three asynchronous traction motors of one bogie are powered from the common frequency converter FC is shown in figure 7. Peculiarities of parallel operation of traction motors are analyzed at the same static resistance moment M_{st} . Due to the inevitable geometrical deviations of parts (wheel set, rail), differences of electrical and magnetic properties of materials, the characteristics of the same type traction motors are different. In the nominal load mode the traction motor rotor speeds may differ $\pm 3\%$. When asynchronous traction motors are powered from one source the currents among parallel traction motors are redistributed due to the natural mechanical characteristics of the same type asynchronous traction motors. Traction motors achieve different respective torques M_1, M_2, M_3 , rotor rotation speeds n_1, n_2, n_3 and develop different traction forces of individual motors.

Natural mechanical characteristics of the same type asynchronous traction motors (ATM) at the same static resistance torque M_{st} at the wheel set force point A are shown in Fig. 8.

Natural mechanical characteristics of the same type ATMs may be formed at the point where synchronous speed is n_0 . When analyzing natural mechanical characteristics of the same type asynchronous torque motors with the same static resistance torque M_{st} at the wheel set force point A it can be seen that the rotation speed of the first ATM rotor n_1 , rotation speed of the second ATM rotor n_2 and rotation speed of the third ATM rotor n_3 do not synchronize. When the wheel set diameter is equal and the speed of traction motor rotor is different, the distance traveled by wheel sets is different. This phenomenon causes wheel set slip conditions and redistribution of traction forces.

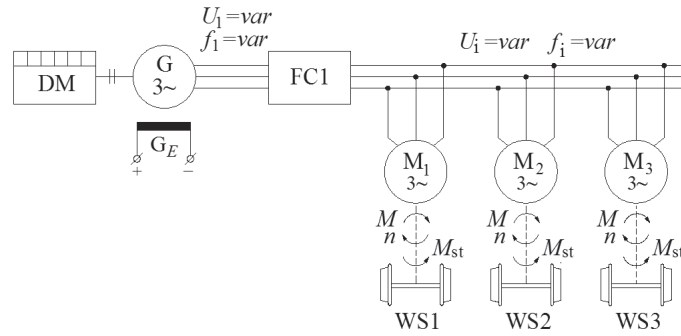

Fig. 7. Circuit diagram of diesel-electric powered locomotive (AC/AC current system) drive, when one frequency converter is used to power three AC traction motors: DM – diesel engine; G – synchronous traction generator; FC1 – frequency converter; M1, M2, M3 – asynchronous traction motors; WS1, WS2, WS3 – wheel-sets; M_{st} – static resistance torque U_p, f_1 - asynchronous traction motor drive parameters

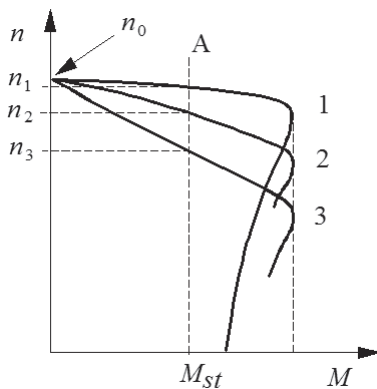

Fig. 8. The same type natural mechanical characteristics of asynchronous traction motors at the same static resistance torque

6. Control systems of asynchronous motors with individual frequency converters

Control systems of asynchronous motors with individual frequency converters are shown in figure 9.

When using ATM control via individual frequency converters, the slipping and sliding process is easier to control as the speed of every traction motor can be adjusted separately. However, this control system is often more complex and less reliable.

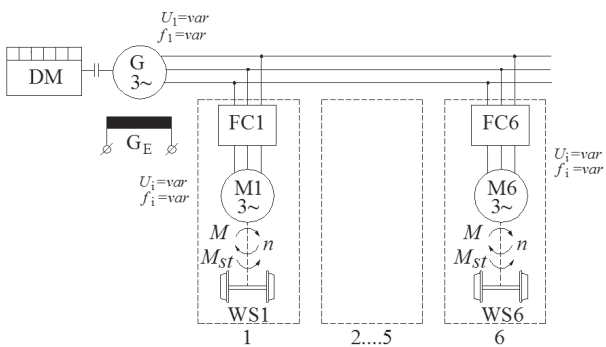

Fig. 9. Control system of asynchronous engines with individual frequency converters: FC1, ..., FC6 – frequency converters; WS1, ..., WS6 – wheel-sets of locomotive

7. Frequency control peculiarities of locomotives with asynchronous traction motors

For locomotives with frequency converter mode of ATM that satisfies traction theory requirements, there is a need to change the nature of natural mechanical characteristics artificially by developing there a part of hyperbolic function. Thus ATM areas of the natural characteristics are shown as A_1, A_2, A_3 (fig. 10). The nature of ATM artificial mechanical characteristics corresponds to DC series excitation DC traction motor mechanical characteristics. Therefore locomotives with ATMs should have installed control systems to control wheel set slipping process. During locomotive wheel set slipping they temporarily change the nature of the ATM artificial mechanical properties and recover the conditions of wheel set adhesion with rails. Computer aided control system for locomotive wheel set slipping and sliding process control that is proposed by the authors will change the nature of ATM artificial mechanical properties and it will automatically recover good conditions of wheel set adhesion to rails. Adjusted ATM dynamic mechanical properties with applied frequency speed control method are provided in fig. 10.

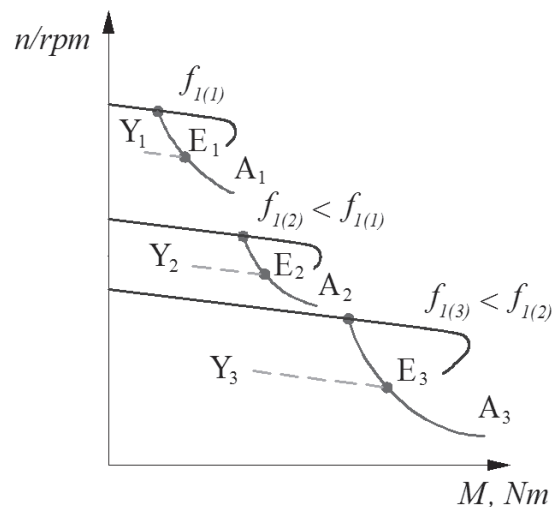

Fig. 10. Artificial asynchronous mechanical characteristics of asynchronous motor when ATM frequency rotation speed control method is applied

8. Automatic control of slipping process of locomotives with AC traction motors

Figure 11 shows AC/AC system that is proposed by the authors for computer aided control of AC/AC system of locomotive wheel set slipping and sliding process that is comprised: wheel set speed sensors BR1- BR6 that are mounted in traction motors, A and B bogie wheel set speed tolerance signal comparison blocks SCBI, SCBII [9]. When tolerance of one of individual wheel sets of bogies (A or B) is exceeded, there are generated control signals A and B that adjust signals sent by computer aided control system (in Fig. 11 marked respectively as X_A and X_B) to inverter elements IGBT transistors that have changing on and off cycles [13].

The automatic control system of slipping process that is proposed by the authors shall decrease the value of supply power and its frequency of one bogie from the three asynchronous engines for a short time. Thus the rotation speed of one bogie of traction motor-wheel set shall be equalized and wheel to rail adhesion shall be restored. Such dynamic characteristics are shown in figure 11 in green as E_1 - Y_1 with supply power frequency $f_1(1)$, E_2 - Y_2 at supply power frequency $f_1(2)$, E_3 - Y_3 with supply power frequency $f_1(3)$. When adhesion conditions are restored, there is automatic restoration of ATM supply power and its frequency value, i.e. it returns to any point of the previous operating characteristic (figure 10). Traction forces are not disrupted in locomotive control process as slipping process is controlled automatically.

9. Algorithm for slipping process parameter adjustment and control

The authors provide computer aided control system of locomotive wheel set slipping and sliding process control. Variants of the control algorithm: a – wheel set speed tolerance signals are compared with the tolerance signals in blocks SCBI, SCBII and they are adjusted by changing parameters of that inverter to control signals Y_1 and Y_3 (thereof the respective three asynchronous traction engines (individual controlled) are powered). b – in case with controlled parameters of inverters I and II the process of bogie wheel set slippage is continued and bogie wheel set speeds are not equalized, the generator voltage of

synchronous traction motor is limited by decreasing excitation current with signal Y_2 (general parameter control).

Computer aided control system of AC/AC current system diesel locomotive wheel set slipping-sliding process consists (figure 11): DM – diesel engine; G – synchronous traction generator; I, II – frequency converters; UCR-uncontrolled rectifier; M1, ..., M6 – asynchronous traction motors; speed sensors of BR traction motors; LD – locomotive driver; SCBI – bogie A wheel set speed tolerance signal comparison unit; SCBII-B – bogie wheel set speed tolerance signal comparison unit; Y_1 – control signal that adjusts inverter I electrical parameters; Y_2 – synchronous traction motor signal that adjusts generator excitation current; Y_3 – control signal that adjusts inverter II electrical parameters; R – excitation current regulator of synchronous traction generator; G_E – excitation winding of synchronous traction generator; $\Delta n_1, \dots, \Delta n_6$ – speed tolerance signals of traction motor; X_A – total compared bogie A wheel set speed tolerance signal; X_B – total compared bogie B wheel set speed tolerance signal.

Authors propose to install an encoder in ATM rotation speed and location coordinate measurement sensors BR that are installed in the traction motor (see figure 12). The encoder is analogous or digital converter with analogous signal at the output or a certain number of pulses that is proportional to rotation speed or turn angle [12].

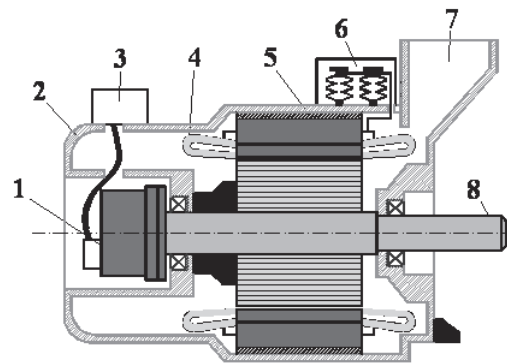

Fig. 12. Asynchronous traction motor with internal optical encoder: 1 – encoder; 2 – stator; 3 – terminal box; 4 – stator windings; 5 – ferromagnetic core; 6 – clamps; 7 – cooling channel; 8 – shaft

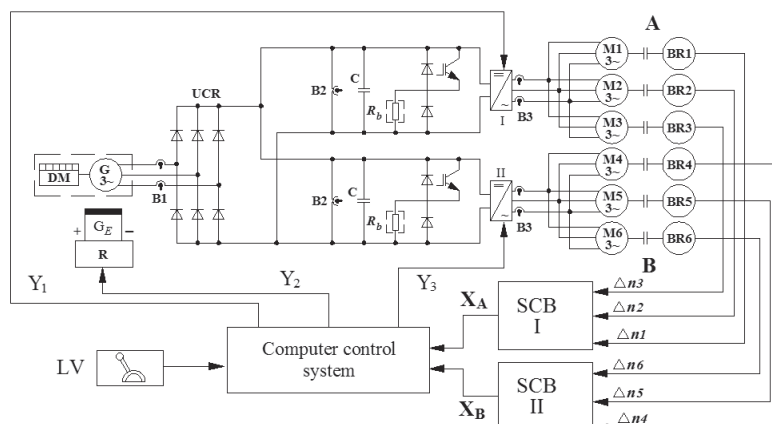

Fig. 11. Circuit diagram of diesel-electric powered locomotive (AC/AC electric system) automatic wheel-sets anti-slip and slide control system process parameters computer drive: SCBI – traction motors speed control block (bogie A); SCBII – traction motors speed control block (bogie B)

To use an encoder in ATM vector control system is suggested by Liudvinavičius et al [10]. The encoder consists of a light source, mask, code disc and sensors. The code disc contains artificial spaces that make light permeable and impermeable segments. Light sensitive sensors are mounted behind the code disc. The scheme of optical encoder is provided in figure 13 [5].

When encoder is installed in the ATM control system that is proposed by the authors, there can be received analogous or digital information, thus developing analogous-digital (hybrid) locomotive electrical drive control system [1, 14].

Pursuant to the purpose, the encoder may contain various codes: binary code, Gray code, Gray-express code [3]. All of them are suitable for computer system of AC/AC current system diesel locomotive wheel set slipping-sliding process control that is proposed by the authors.

10. Tests of locomotive wheel set slipping and sliding process computer aided control and management system

10.1. Locomotive tests description

The software performs the several tasks. It ensures highly-efficient wheel-to-rail force transmission by means of continuous wheel force at its rim; slip control; limitation of wheel acceleration; reliable determination of the reference speed, which should represent the true train speed.

The software protects the mechanical components against excess stress and reduces wear on the rails and wheel-set by avoiding: wheel blocking (flat spots on the running surface); synchronous drifting of the wheel speeds (worn rail heads); inherently stable rotational vibrations in the drive train.

The software continuously monitors the movement of the vehicle and the running wheels. If the movement variables deviate from the tolerance values, the tractive effort demanded by the overall control level is automatically reduced to a level which can be physically transmitted from the wheel to the rail.

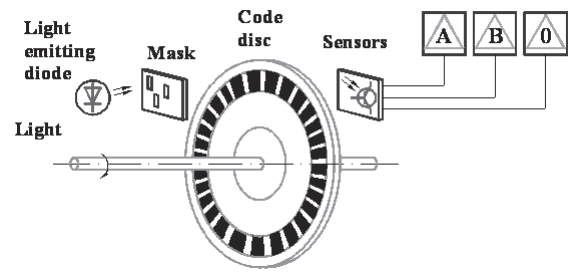

Fig. 13. Optical encoder scheme

Due to continuous monitoring of the movement variables relating to the vehicle and the wheels, it is ensured that traction is kept under control under different track conditions.

Power mode: The test train is accelerated from standstill to maximum speed. All wheel speeds are monitored via the data logger to confirm the proper functionality.

Dynamic brake only: The test train is decelerated from maximum speed to standstill with the dynamic brake.

Dynamic and pneumatic brake: The test train is decelerated from maximum speed to standstill with the dynamic and the independent brake.

This is not a normal service operation. It shows, that the wheel slide is corrected via signals transmitted from the pneumatic wheel slide system to the *Locomotive Computer Unit* for the limitation of electric brake in case of active pneumatic brake.

10.2. Valuation of tests results

AC/AC system diesel-electric powered locomotive wheels slip and slide computer control results are presented in Fig. 14.

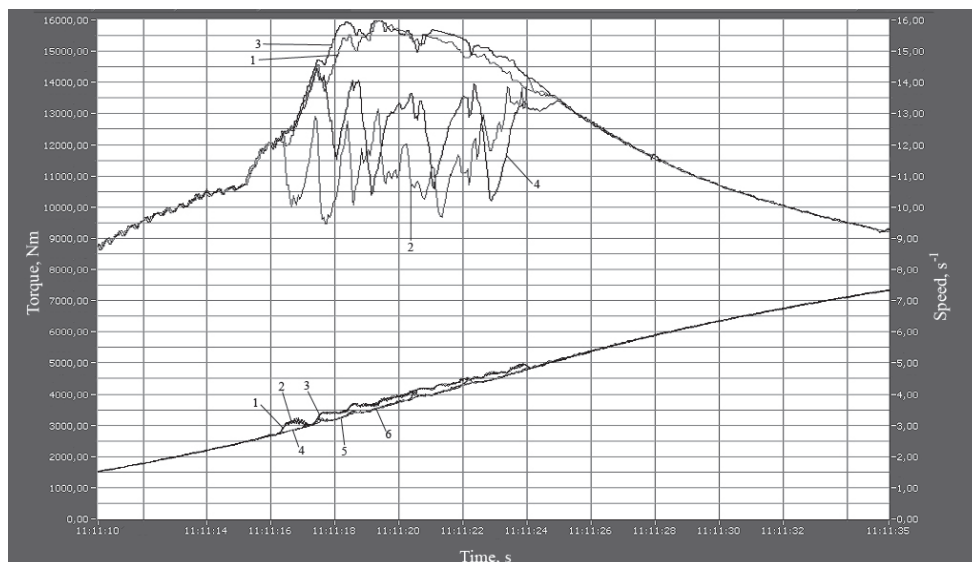

Fig. 14. AC/AC system diesel-electric powered locomotive test characteristics: Upper lines left scale: 1 – 1st bogie torque 1 reference before slip and slide control; 2 – 1st bogie torque after slip and slide control; 3 – 2nd bogie torque reference before slip and slide control; 4 – 2nd bogie torque after slip and slide control; Lower lines right scale: 1 – 1st wheel-set speed; 2 – 2nd wheel-set speed; 3 – 3rd wheel-set speed; 4 – 4th wheel-set speed; 5 – 5th wheel-set speed; 6 – 6th wheel-set speed

11. Conclusions

1. The non-traditional computer aided slipping and sliding control system of locomotive AC traction motors that is proposed by the authors allows automatic continuous control of electrical parameters of the inverter and traction generator in traction mode (dynamic mode) with the simultaneous slipping process control.
2. When the provided slip and slide control system of locomotives with AC traction motors is used, train driver does not need to interrupt traction mode control and this way there are no conditions for the formation of the rolling stock longitudinal tensile and compression forces.
3. When the provided slip and slide control system of locomotives with AC traction motors is used, there is optimal traction force control.
4. When the provided slip and slide control system of locomotives with AC traction motors is used, there are less energy transformation losses in internal combustion engines.
5. When the provided slip and slide control system of locomotives with AC traction motors is used, the adhesion coefficient is little dependant on the season.
6. When the provided slip and slide control system of locomotives with AC traction motors is used, the adhesion coefficient is recovered automatically and there is no need to put sand under the wheels to increase the adhesion.

12. References

1. Antoniuk J. Urządzenia i systemy transportu podziemnego w kopalniach. Katowice: Wydawnictwo Śląsk, 1990.
2. Bąk R, Burczyński T. Wytrzymałość materiałów z elementami ujęcia komputerowego. Warszawa: WNT, 2001.
3. Braess H H, Seiffert U. Vieweg Handbuch Kraftfahrzeugtechnik. Friedrich Vieweg & Sohn Verlagsgesellschaft GmbH, Wiesbaden. 2000.
4. Bureika G. A Mathematical Model of Train Continuous Motion Uphill. *Transport* 2008; 23(2): 135-137.
5. Encoder catalogue. Kübler Catalogue. Germany. 2003. 171 p.
6. Fuest K, Döring P. Elektrische Maschine und Antriebe. Lehr- und Arbeitsbuch. Vieweg, Wiesbaden.
7. Jastremskas V, Vaičiūnas G, Černašėjus O, Rudzinskas V. Investigation into the mechanical properties and metal creaks of a diesel locomotive wheel. *Transport* 2010; 25(3): 287-292.
8. Lingaitis L P, Liudvinavičius L. Electric drives of traction rolling stocks with AC motors. *Transport* 2006; 21(3): 223-229.
9. Liudvinavičius L, Lingaitis L P. New locomotive energy management systems. *Eksplotacija i Niezawodnosc - Maintenance and Reliability* 2010; 45(1): 35-41.
10. Liudvinavičius L, Lingaitis L P, Dailydka S, Jastremskas V. The aspect of vector control using the asynchronous traction motor in locomotives. *Transport* 2009; 24 (4): 318-324.
11. Liudvinavičius L, Lingaitis L P. Electrodynamics braking in high-speed rail transport. *Transport* 2007; 22(3): 178-186.
12. Precision inductosyn position transducers for industrial automation, aerospace and military application. *Farrand Controls information Issue*. USA. 1996. 15 p.
13. Sen P C. Principles of Electric Machines and Power Electronics. New York-Chichester-Brisbane-Toronto-Singapore-Weinheim. John Wiley&Sons. 1996.
14. Stölting H-D. Elektronisch betriebene Kleinmaschine. Vorlesungsmanuskript. Universität Hannover, 2002.
15. Strekopytov V V, Grishchenko A B, Kruchek V A. Electric drives of the locomotives. Moscow: Marshrut. 2003; 305 p.
16. Vaičiūnas G, Lingaitis L P. The influence of railroad curves on the wear of lubricated and unlubricated wheel flangs. *Eksplotacija i Niezawodnosc - Maintenance and Reliability* 2010; 47(3): 40-43.

Lionginas LIUDVINAVIČIUS, M. Sc., Eng.

Prof. dr hab. Leonas Povilas LINGAITIS

Prof. dr Gintautas BUREIKA

Department of Railway Transport,

Vilnius Gediminas Technical University,

J. Basanavičiaus 28, LT-03224 Vilnius, Lithuania

e-mail: liong@vgtu.lt; leonasl@vgtu.lt; gintautas.bureika@vgtu.lt
